

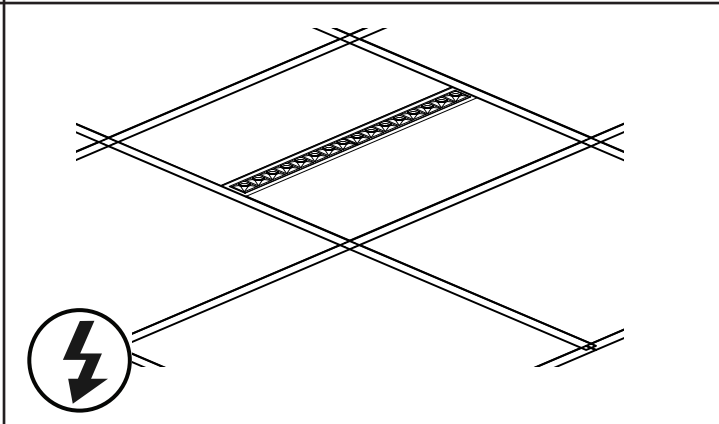

Inspire R 600 Dali

IP20 DALI-2 **PUSH DIM**
220-240V, 50/60Hz

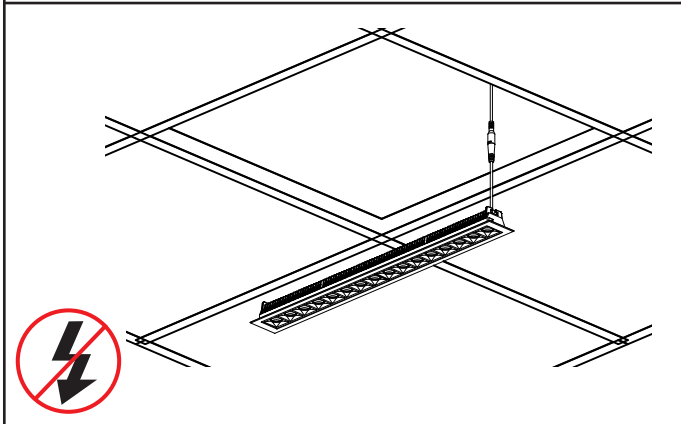
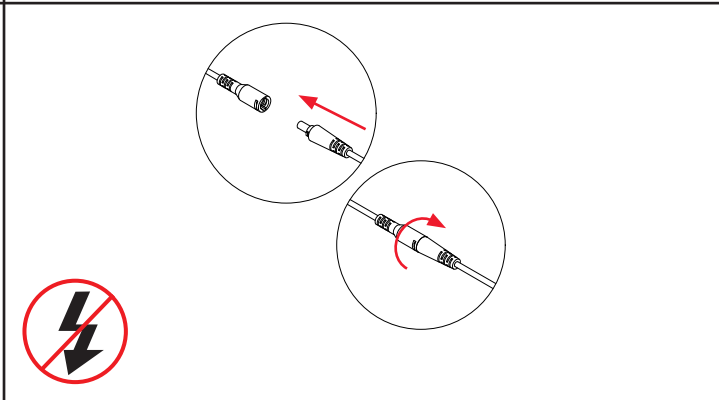
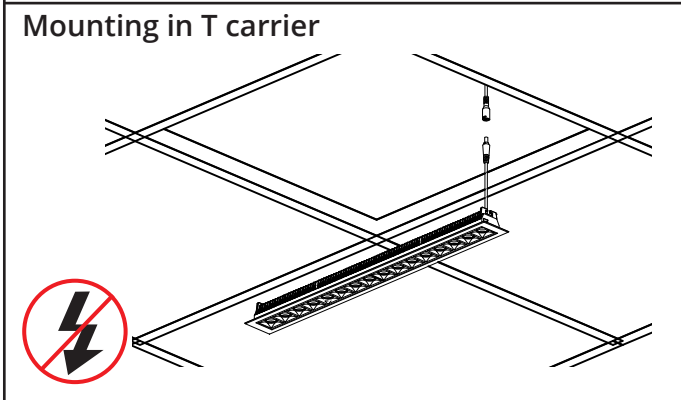
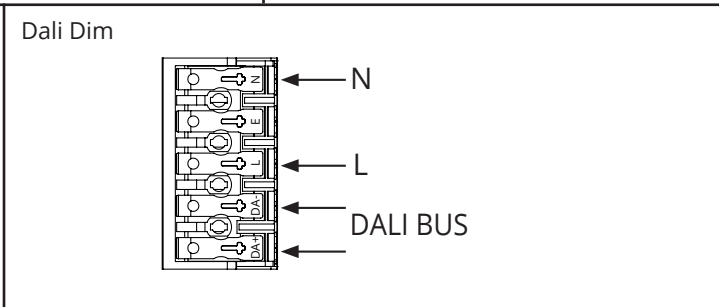
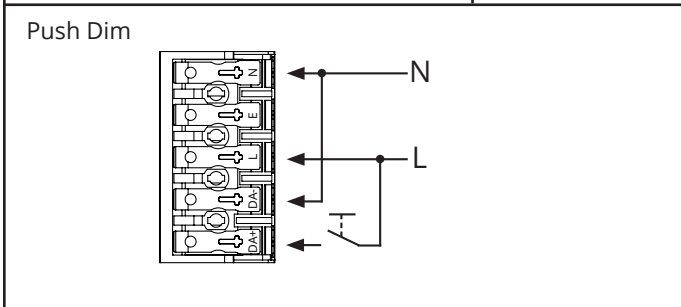
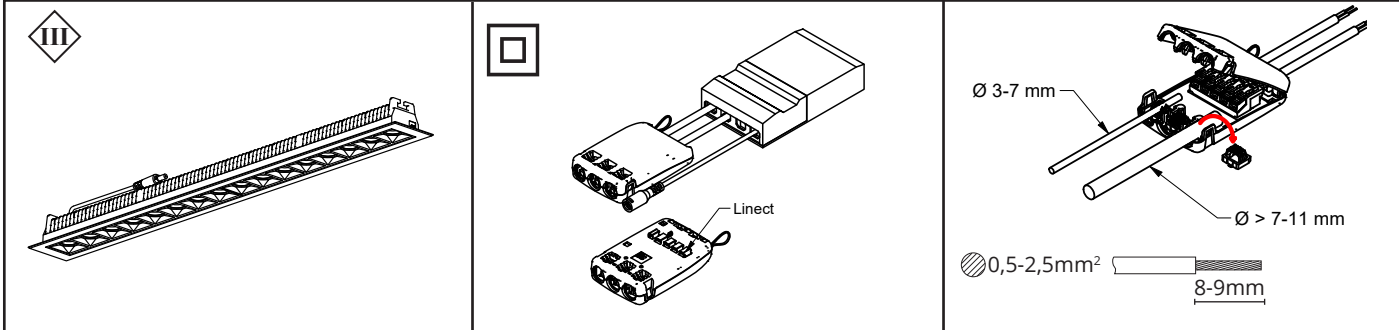

NORWAY
SG Armaturen AS
Skytterheia 25
N-4790 Lillesand

SWEDEN
SG Armaturen AB
Tel: +46 31 81 71 10
info@sg-ab.se
www.sg-ab.se

GERMANY
SG Leuchten GmbH
Tel: +49 40 23 99 44 59
info@sg-leuchten.de
www.sg-leuchten.de

FRANCE
SG Lighting SA/NV
Tel: +33(0) 4 94 93 00 00
info.france@sglighting.fr
www.sglighting.net

SWITZERLAND
SG Leuchten SA
Tel: + +41 44 868 20 00
info@sg-leuchten.ch
sg-leuchten.ch

Tel: +47 37 50 03 00
firmapost@sg-as.no
www.sg-as.no

DENMARK
SG Armaturen A/S
Tel: +45 70 70 72 13
info@sg-as.dk
www.sg-as.dk

FINLAND
SG Armaturen Oy
Tel: +358 02 07 30 39 60
info@sg-oy.fi
www.sg-oy.fi

BENELUX
SG Lighting SA/NV
Tel: +32(0) 15 20 72 71
info.benelux@sglighting.net
www.sglighting.net

INTERNATIONAL
SG Lighting Co Ltd.
Tel: +86 769 88 49 20 88
cindy@sgdgc.com
www.sg-as.com

Recessed Ceiling Mounting

Spring for recessed mounting sold separately

Product no.: 320908

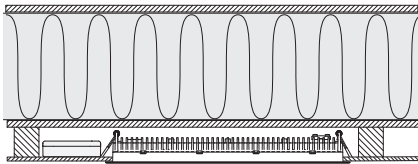
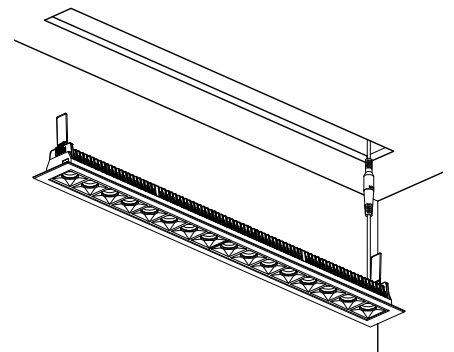
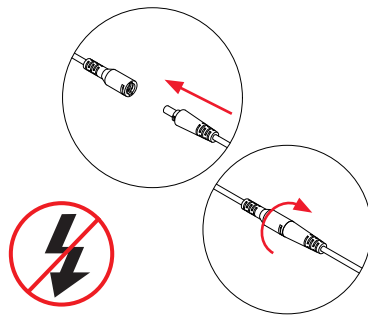
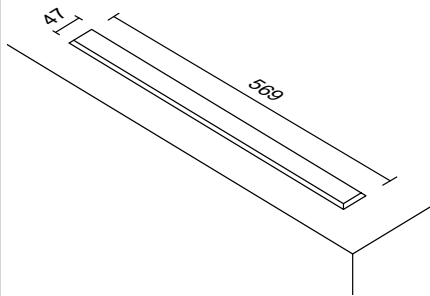
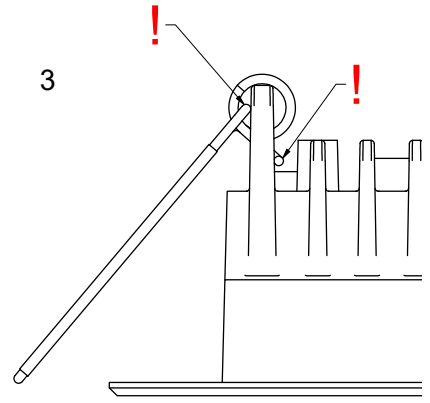
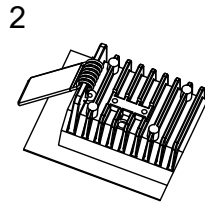
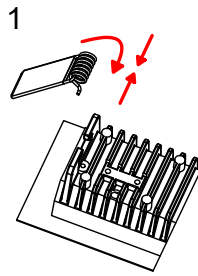
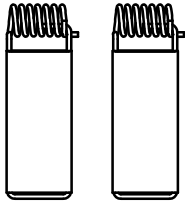

Dipswitch settings

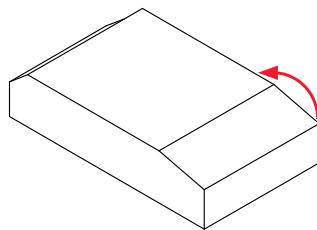

Standard

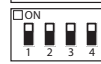
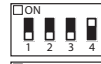

mA	Im	UGR	IsoSafe
300	50%	<19	Yes
350	58%		
400	67%		
450	75%		
500	83%		
550	92%		
600	100%	<22	No
650	107%		
700	114%		
750	121%		
800	128%		
850	135%		
900	143%		
950	150%		
1000	157%		
1050	163%		

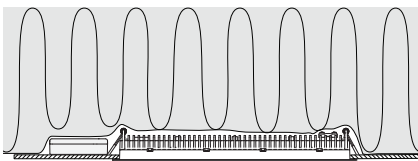

Max 500 mA

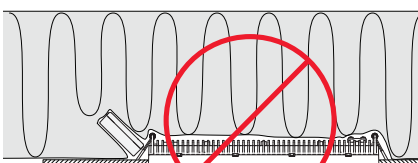

2: Replaceable (LED only)
light source by a professional



3: Replaceable control gear
by a professional



NO: Kan kun installeres og vedlikeholdes av en registrert installasjonsvirksomhet.

DK: Må kun installeres og vedligeholdes af uddannet elektriker.

SE: Skall installeras och underhållas av behörig elektriker.

EN: Only to be installed and maintained by an authorized electrician.

FR: Doit être installé et maintenu par un électricien qualifié.

NL: Mag alleen geïnstalleerd en onderhouden worden door een bevoegde electricien.

DE: Dieses Produkt darf nur durch autorisiertes Personal (z.B. Elektro-Installateur) angeschlossen, in Betrieb genommen und gewartet werden.

FI: Asentaa ja huoltaa saa vain valtuutettu sähköasentaja

NO: Skru av strømmen før montering.

DK: Sluk for strømmen inden montering.

SE: Stäng av strømmen innan montering.

EN: Turn off power before installing.

FR: Couper le courant avant l'installation.

NL: Stroom uitschakelen voor u het toestel installeert.

DE: Vor Installationsarbeiten den Strom abschalten.

FI: Sammuta virta ennen kytkemistä

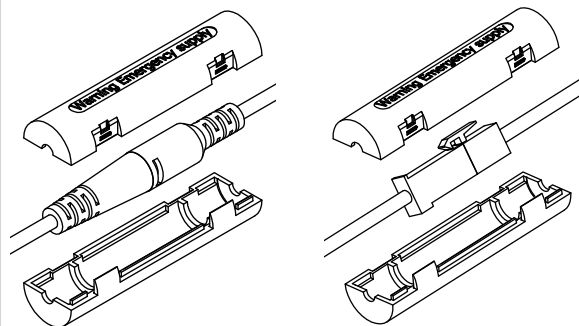

DK: I Frankrig og Danmark er en permanent forbindelse påkrævet af sikkerhedsbelysningsforskrifterne!

For Danmark og Frankrig er det nødvendigt at sikre twistforbindelsen ved at montere løsning med ekstra koblingslås - brug følgende produkt som skal bestilles separat: 8241000276

FR: En France et au Danemark, une connexion permanente est exigée par la réglementation pour l'éclairage de sécurité !

Pour le Danemark et la France, il est indispensable de sécuriser la connexion torsadée en équipant la solution d'un verrou de connexion supplémentaire - utilisez le produit suivant, qui doit être commandé séparément : 8241000276